



# **Demonstrating the Economic Benefits of GFRP Reinforced Bridge Decks**

**Kent Kostuk, Ph.D., P.Eng.**

**Gordon Sparks, Ph.D., P.Eng.**

**Mohamed Boulfiza, Ph.D.**

**Paul Christensen, B.A., M.A., Ph.D.**

**Gamil Tadros, Ph.D, P.Eng.**

**CDCC 2007**

**May 22-24, 2007**

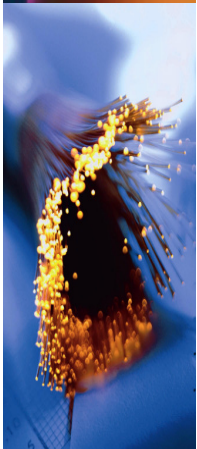

# Summary of Methodology

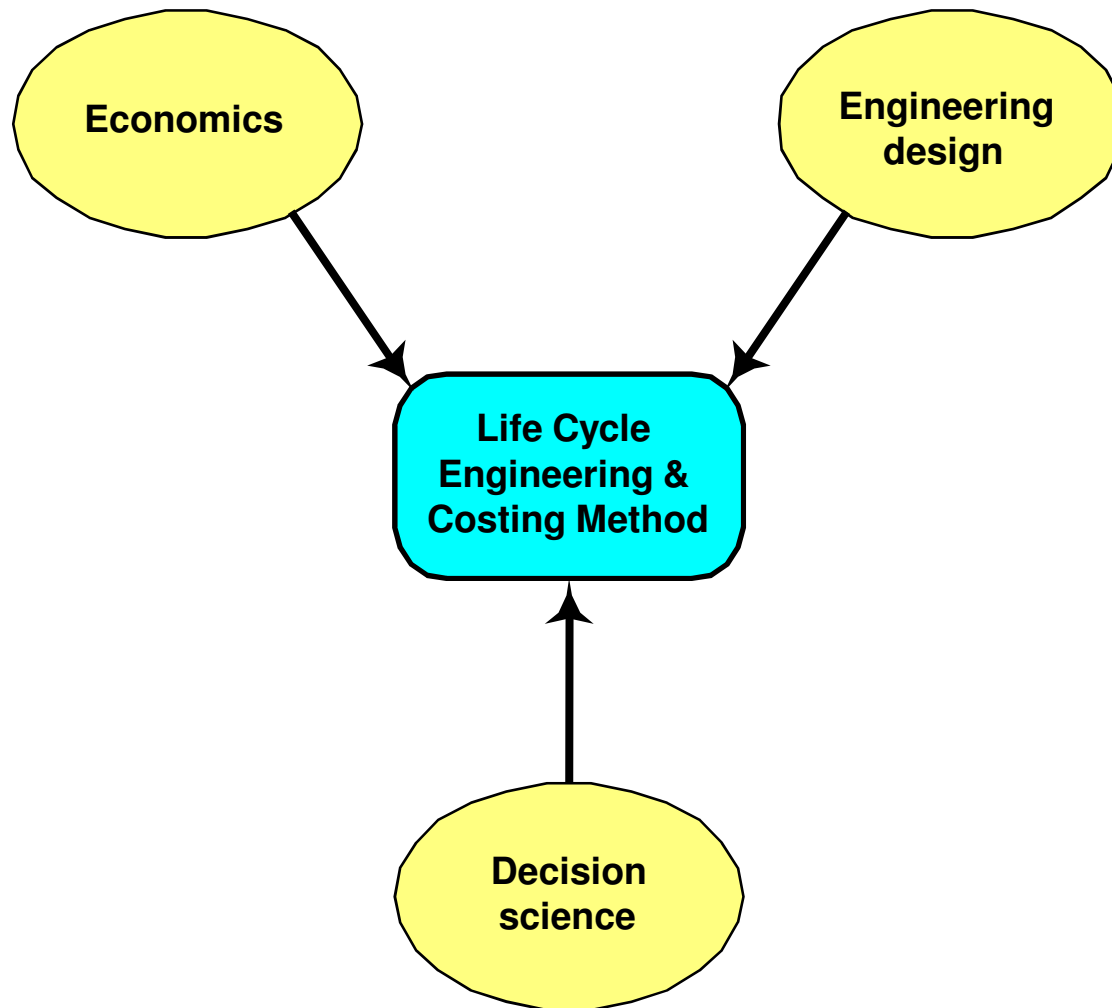

# Why Life Cycle Engineering and Costing?

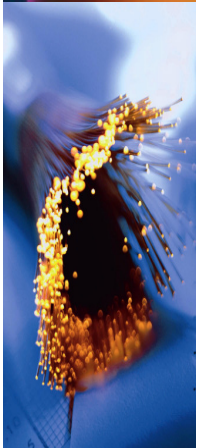

# Why Innovative Materials?

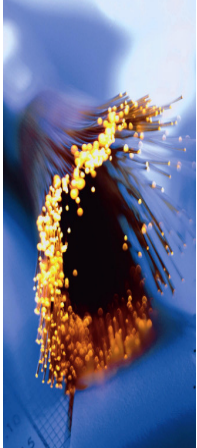
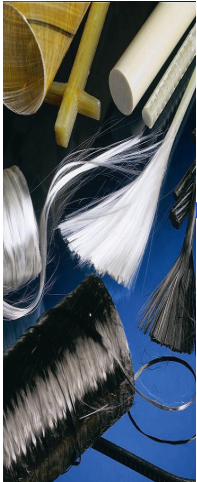

# Why Innovative Design?

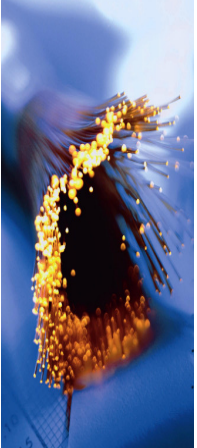

### Canadian Taxpayers:

- Can no longer afford to replace and expand our civil infrastructure using old methods!
- We must find a better way!

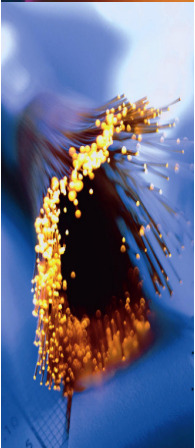

### The Better Way:

- Base decisions on engineering for the “life cycle”
- Minimizing life cycle costs
- Exploit the benefits of:
  - best methods for situation
  - innovative materials
  - innovative designs!

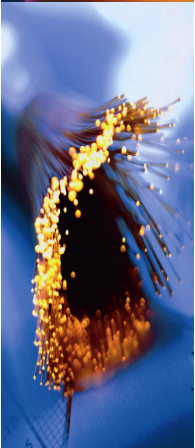

## Bridge Deck Application

---

- **An Illustrative Example**
  - Not exhaustive
  - Considering only 4 reinforcing materials

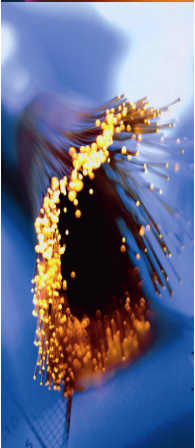

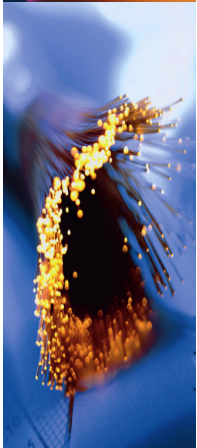
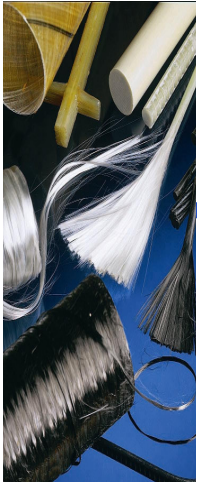

# ALTERNATIVE 1: BLACK STEEL

# Alternative 1: Black Steel

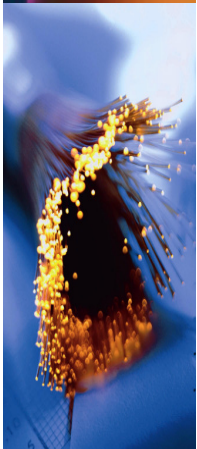
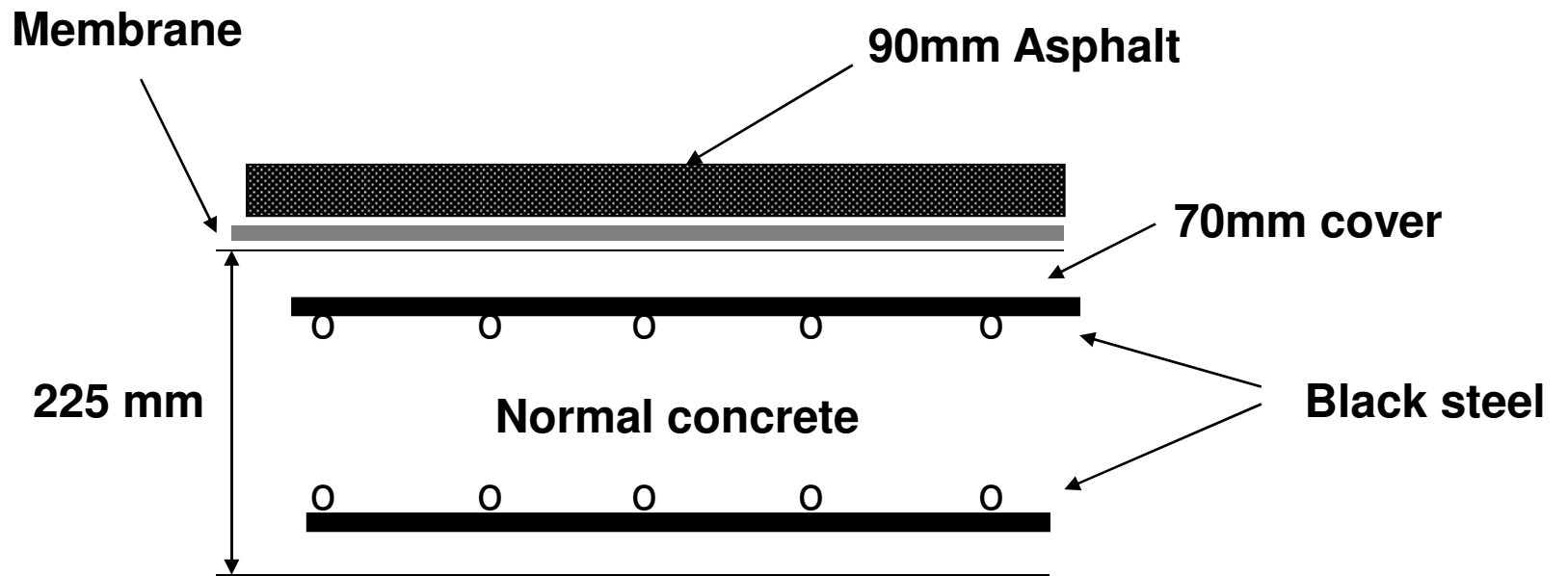

# Alternative 1: Black Steel

Chloride ions penetrate deck  
Chloride ions reach membrane  
Damage to membrane  
Chloride ions penetrate membrane  
Chloride ions reach upper reinforcement

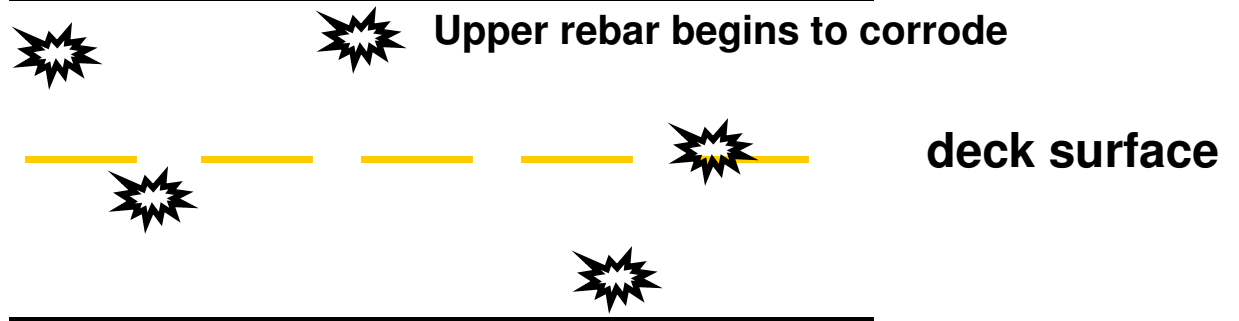

Cross-Section

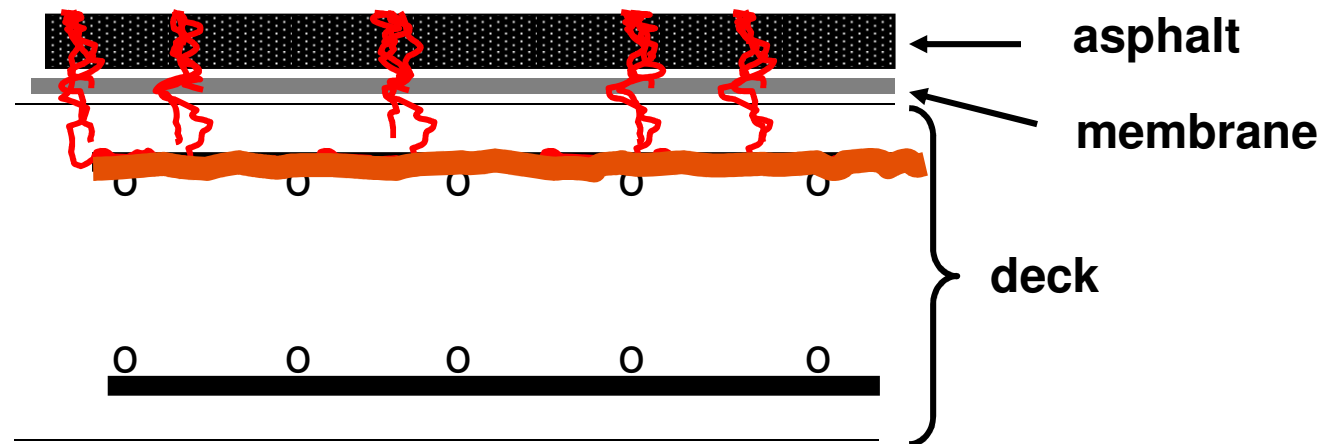

## Alternative 1: Black Steel

### After approximately 25 years:

- Asphalt surface needs to be rehabilitated again
- Membrane requires replacement
- Upper reinforcement seriously corroded at various locations (e.g. over piers)

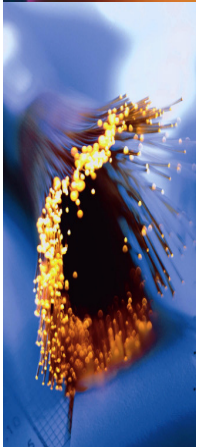
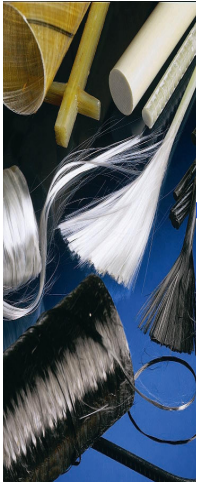

# Alternative 1: Black Steel

## Cash Flow Diagram (over 100 year life):

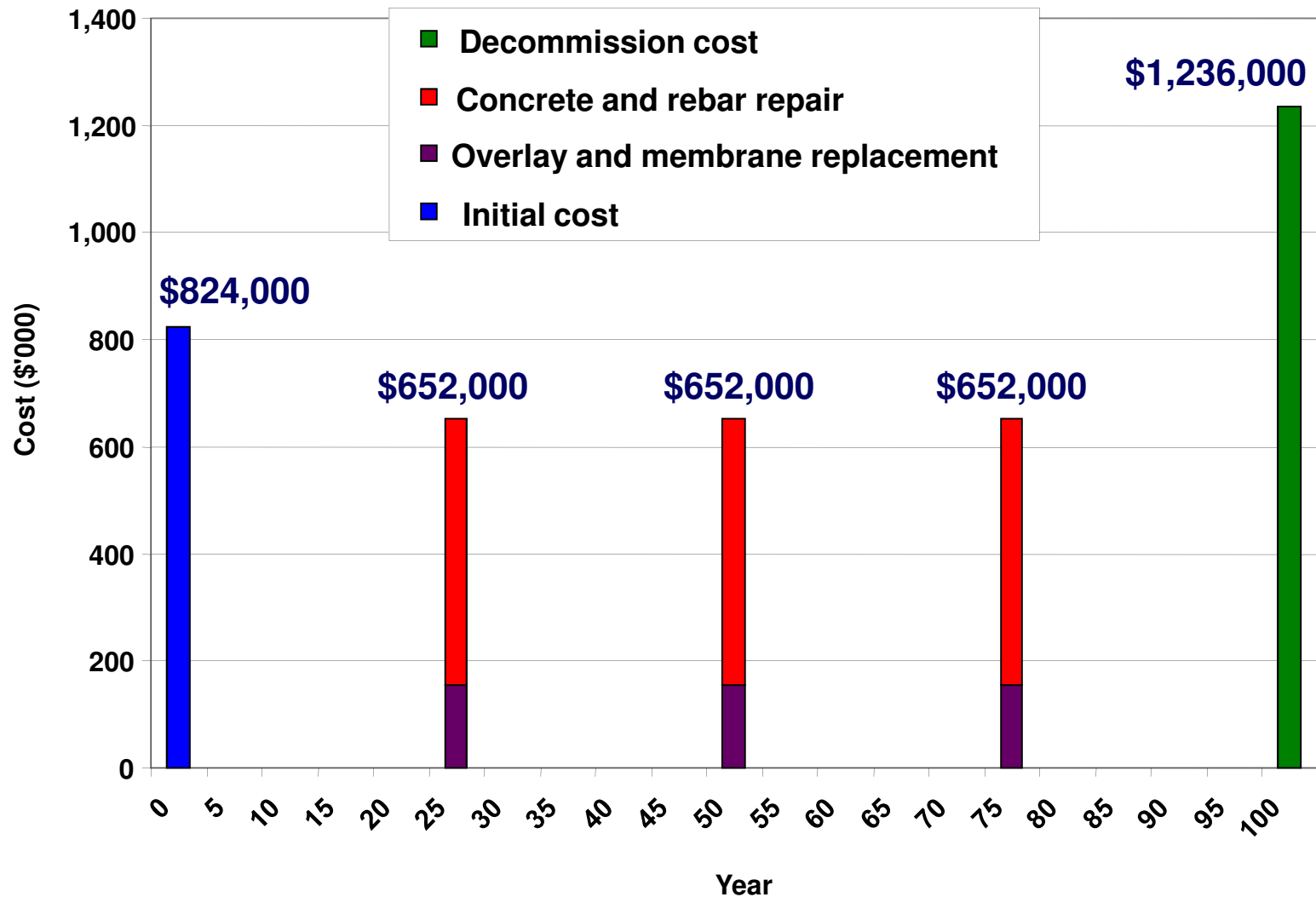

**This is NOT the end of the story**

- **Results based on FIXED parameter estimates**
- **Do we believe them?**
- **What if they're wrong?**
- **Does our uncertainty matter?**

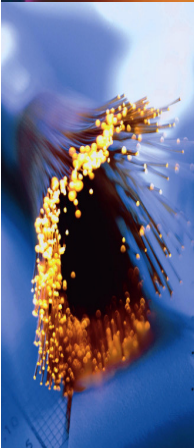

# Addressing Uncertainty: Profile of Life Cycle Costs

## A Conceptual Example

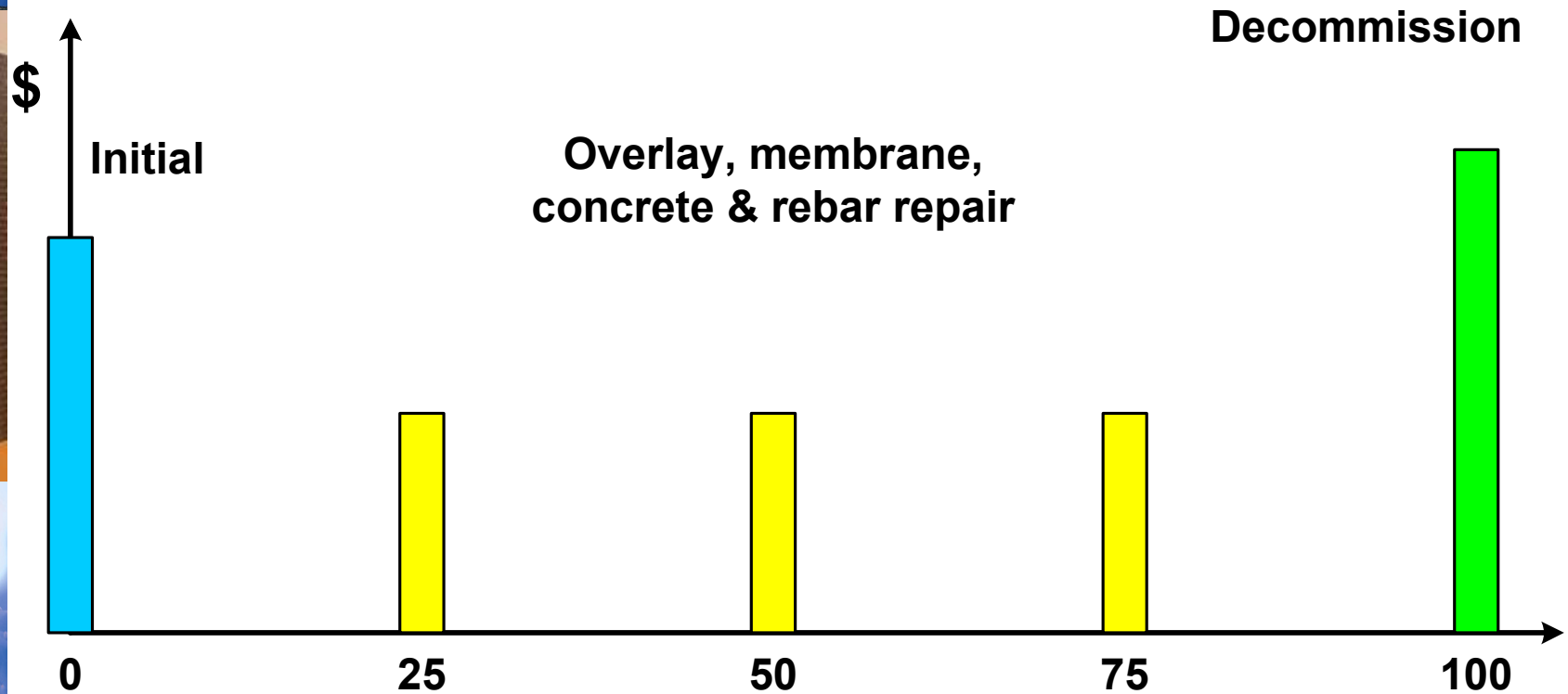

# Addressing Uncertainty: Profile of Life Cycle Costs

Costs can vary substantially due to uncertainty in predicting variables

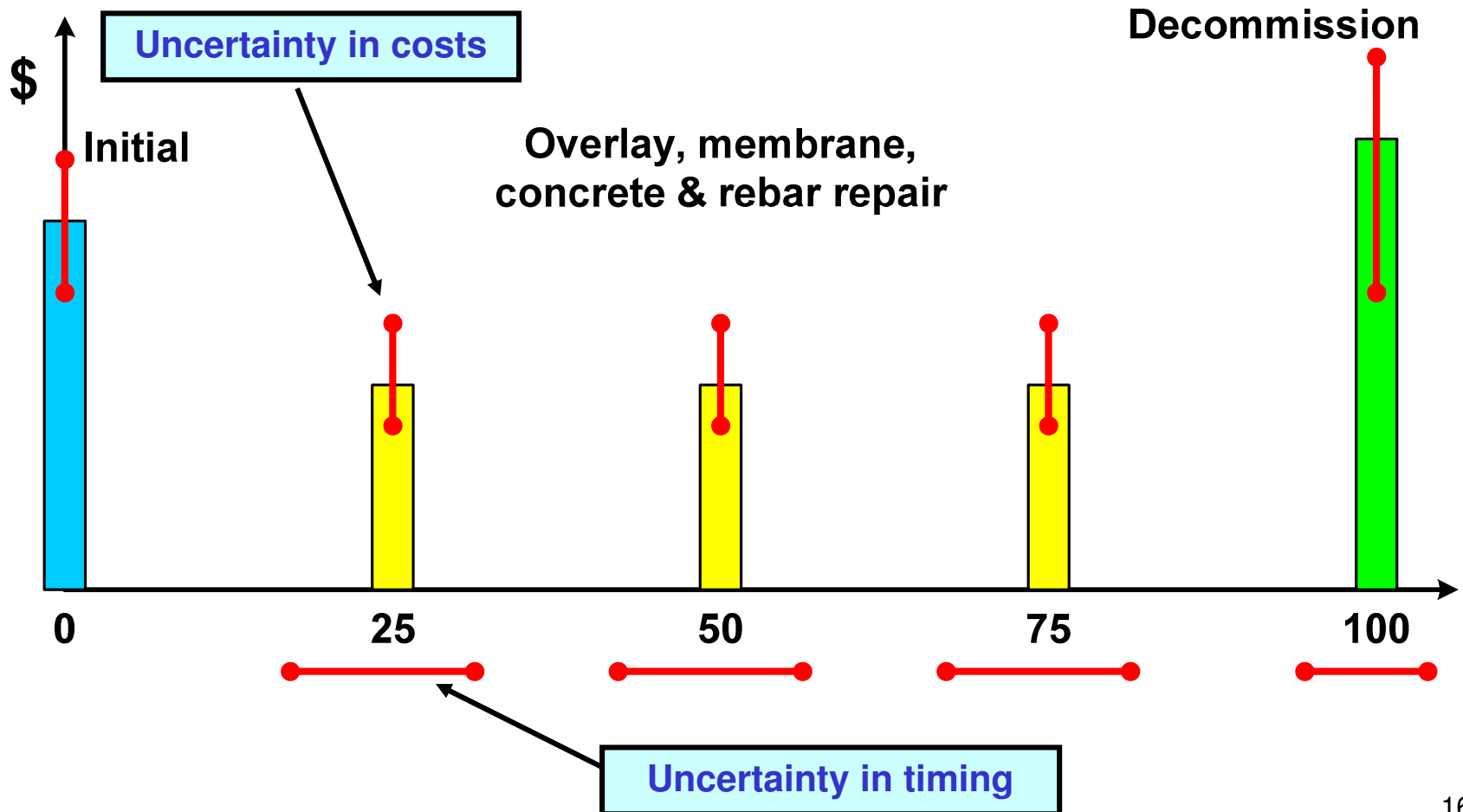

# Excel LCC Spreadsheet Model & Data

Cell Name	Alternative 1: Black / Black (Internal + AC + membrane + NC)			Alternative 2: Epoxy / Epoxy (Internal + AC + membrane + HPC)			Alternative 3: SS / Black (Internal + AC + membrane + HPC)			Alternative 3b: GFRP / GFRP (Internal + HDO + HPC)			Alternative 4: GFRP / GFRP (External + HDO + HPC)			
	Low	Nominal	High	Low	Nominal	High	Low	Nominal	High	Low	Nominal	High	Low	Nominal	High	
Discount rate	5.0%	5.0%	5.0%	5.0%	5.0%	5.0%	5.0%	5.0%	5.0%	5.0%	5.0%	5.0%	5.0%	5.0%	5.0%	
Study period (years)	100	100	100	100	100	100	100	100	100	100	100	100	100	100	100	
<b>Deck design dimensions</b>																
Deck length (m)	304.5	304.5	304.5	304.5	304.5	304.5	304.5	304.5	304.5	304.5	304.5	304.5	304.5	304.5	304.5	304.5
Deck width (m)	11.8	11.8	11.8	11.8	11.8	11.8	11.8	11.8	11.8	11.8	11.8	11.8	11.8	11.8	11.8	11.8
Roadway width (m)	10.4	10.4	10.4	10.4	10.4	10.4	10.4	10.4	10.4	10.4	10.4	10.4	10.4	10.4	10.4	10.4
- Proportion over piers	0.45	0.45	0.45	0.45	0.45	0.45	0.45	0.45	0.45	0.45	0.45	0.45	0.45	0.45	0.45	0.45
Deck thickness (mm)	225	225	225	225	225	225	200	200	200	200	200	200	200	200	200	200
<b>Initial costs</b>																
Unit costs																
- Overlay (\$/m2)	15	20	25	15	20	25	15	20	25	60	70	80	60	70	80	80
- Membrane (\$/m2)	40	45	50	40	45	50	40	45	50	0	0	0	0	0	0	0
- Concrete for deck (\$/m3)	500	600	700	630	700	770	630	700	770	630	700	770	630	700	770	770
- Rebar (\$/m2)																
- Top mat	13	20	30	19	28	42	109	125	144	35	40	46	13	15	17	17
- Bottom mat	13	20	30	19	28	42	13	20	30	73	84	97	13	15	17	17
- Mat over piers	0	0	0	0	0	0	0	0	0	0	0	0	0	0	0	0
- Straps (\$/m2)	0	0	0	0	0	0	0	0	0	0	0	0	30	37	48	48
<b>Rehabilitation and maintenance costs</b>																
Unit costs																
- Deck survey (\$/m2)	7	7	7	7	7	7	7	7	7	7	7	7	7	7	7	7
- # of deck surveys prior to overlay	2	2	2	2	2	2	1	1	1	0	0	0	0	0	0	0
- Traffic control (\$/day)	1,500	2,000	3,500	1,500	2,000	3,500	1,500	2,000	3,500	1,500	2,000	3,500	1,500	2,000	3,500	3,500
- Overlay days	5	5	5	5	5	5	5	5	5	5	5	5	5	5	5	5
- Incremental concrete repair days	16	16	16	16	16	16	5	5	5	0	0	0	0	0	0	0
- Overlay removal (\$/m2)	2	2	2	2	2	2	2	2	2	15	20	30	15	20	30	30
- Concrete removal																
- Shallow depth "above top rebar" (mm)	50	50	50	50	50	50	50	50	50	50	50	50	50	50	50	50
- % of road surface area affected	20%	40%	100%	10%	25%	45%	5%	10%	15%	1%	3%	5%	1%	3%	5%	5%
- Removal cost (\$/m2)	86	100	150	120	150	200	120	150	200	120	150	200	120	150	200	200
- Partial depth "below top rebar" (mm)	125	125	125	125	125	125	100	100	100	100	100	100	100	100	100	100
- % of road surface area affected	20%	25%	35%	5%	10%	20%	2%	4%	8%	1%	1%	1%	1%	1%	1%	1%
- Removal cost (\$/m2)	190	200	300	216	270	360	216	270	360	216	270	360	216	270	360	360
- Concrete replacement (\$/m3)	1,000	1,200	1,400	1,200	1,600	2,000	1,200	1,600	2,000	1,200	1,600	2,000	1,200	1,600	2,000	2,000
- Unit top mat rebar replacement cost (\$/m2)	13	20	30	19	28	42	109	125	144	35	40	46	13	15	17	17
<b>Treatment 1: replace 1/2 overlay</b>																
- Treatment 1 necessary?	1	1	1	1	1	1	1	1	1	0	0	0	0	0	0	0
- Cycle (years)	20	25	25	20	25	25	20	25	25	60	75	100	60	75	100	100
<b>Treatment 2 &amp; 3 combined</b>																
- Cycle (years)	20	25	40	25	35	45	60	75	100	60	75	100	60	75	100	100
<b>Decommissioning costs</b>																
Unit deck decommissioning costs (\$/m2)	340	350	380	340	350	360	340	350	360	340	350	380	340	350	380	380



# Alternative 1: Black Steel Tornado Plot

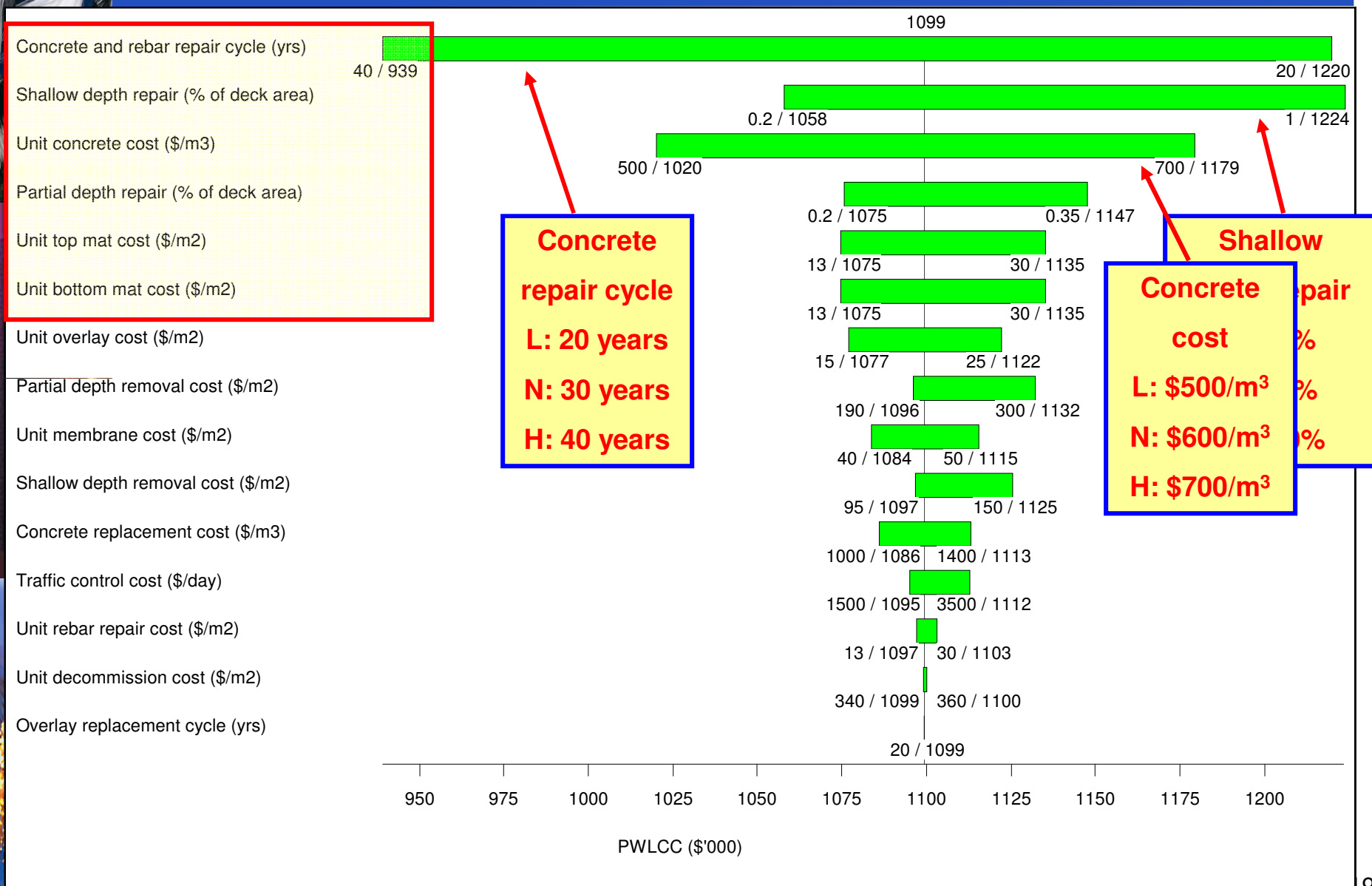

# Alternative 1: Black Steel Distribution of Life Cycle Costs

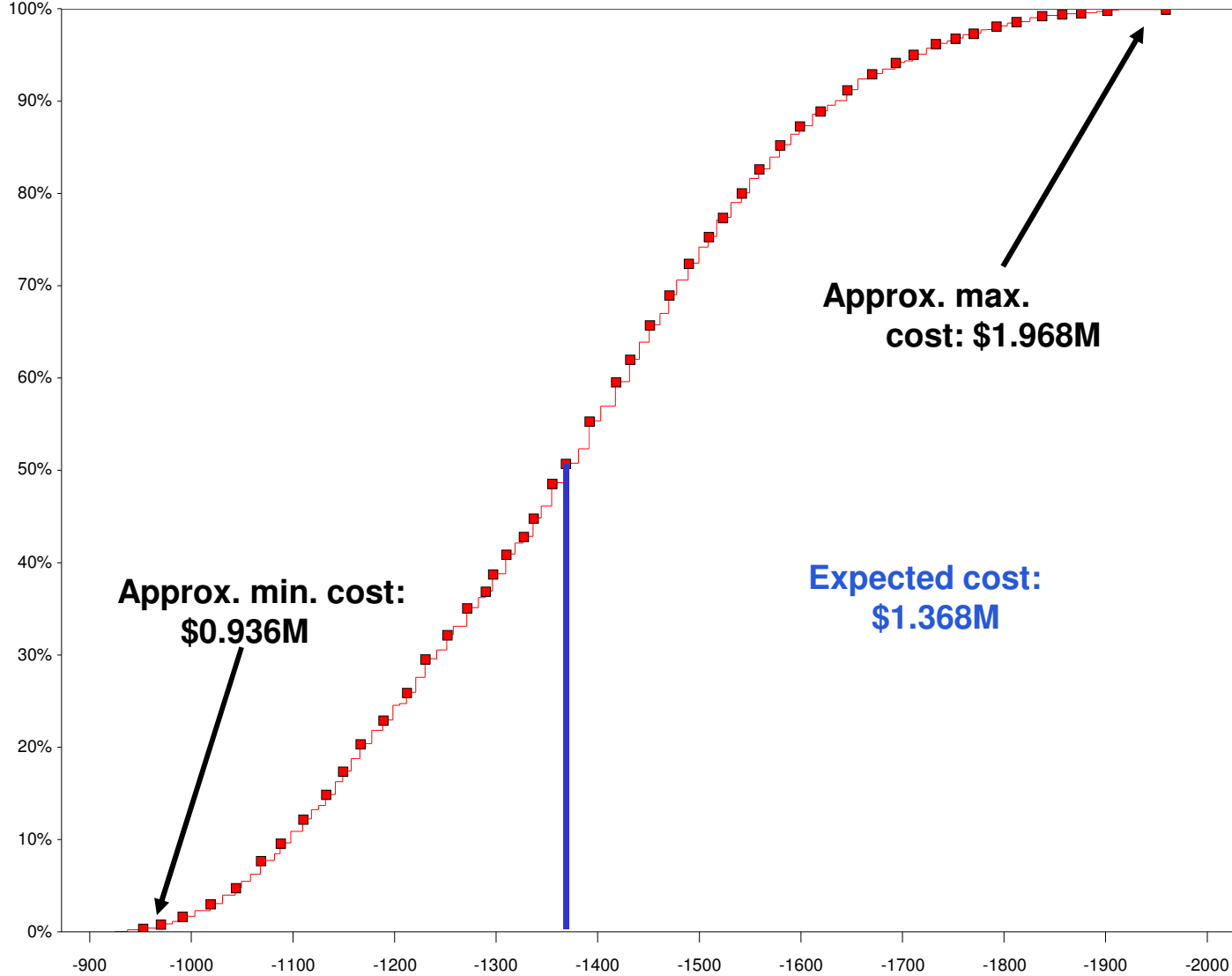

# Summary of Expected Value of Life Cycle Costs



Alternative	EVPW (\$M)
1. Black Steel	1.368
2.	
3.	
4.	
5.	

## Alternative 1: Black Steel

---

**How can we improve on Alternative 1:**

- **Improve performance of reinforcing bars**
- **Use High Performance Concrete (HPC) in deck**

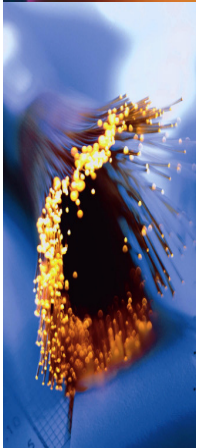

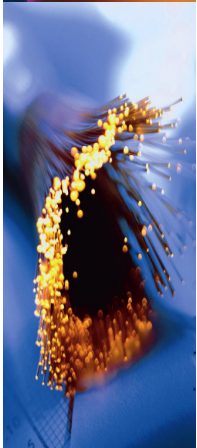
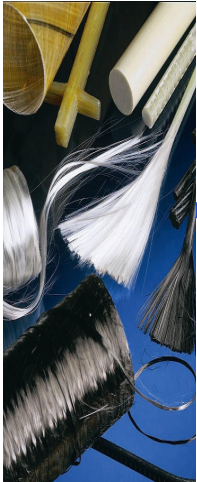

---

## **ALTERNATIVE 2: EPOXY-COATED STEEL**

## Alternative 2: Epoxy-Coated

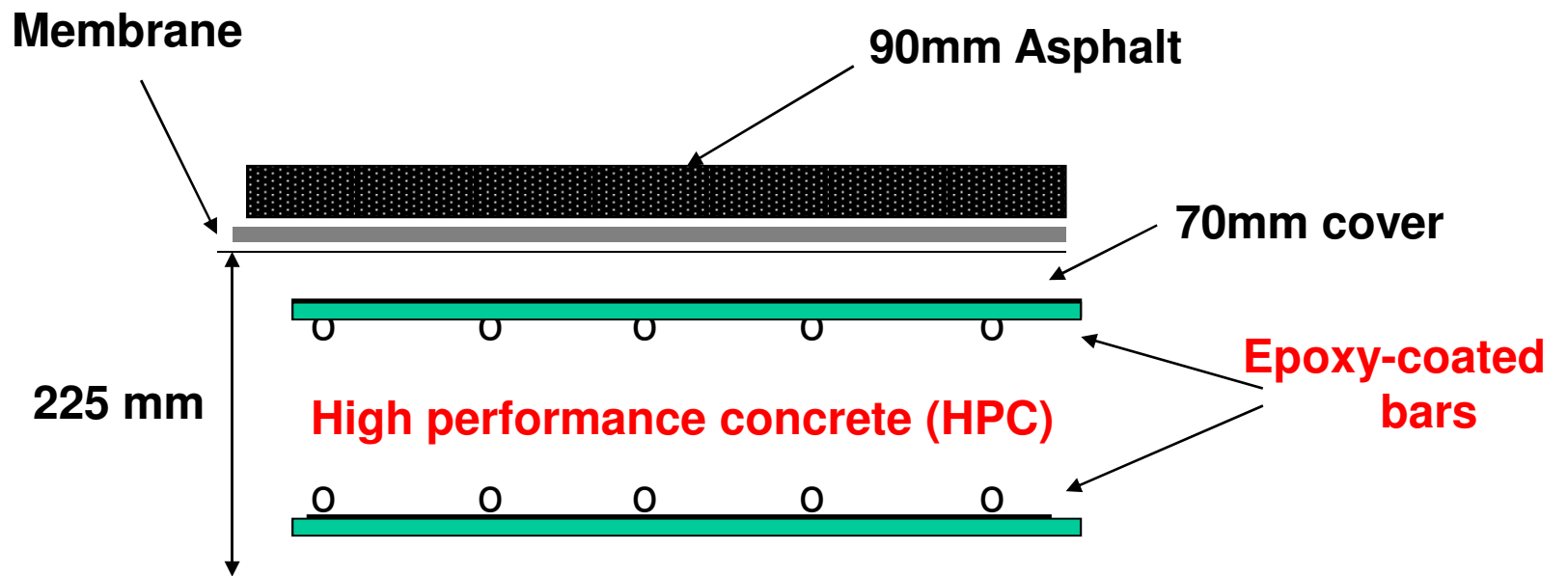

## Alternative 2: Epoxy-Coated

---

### Benefits over Alternative 1 (black steel):

- Bar coating & HPC in deck slows chloride penetration
  - (But, as it turns out, not by much)

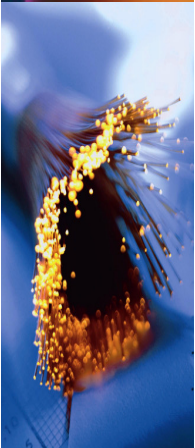

## Alternative 2: Epoxy-Coated

### Cash Flow Diagram (over 100 year life):

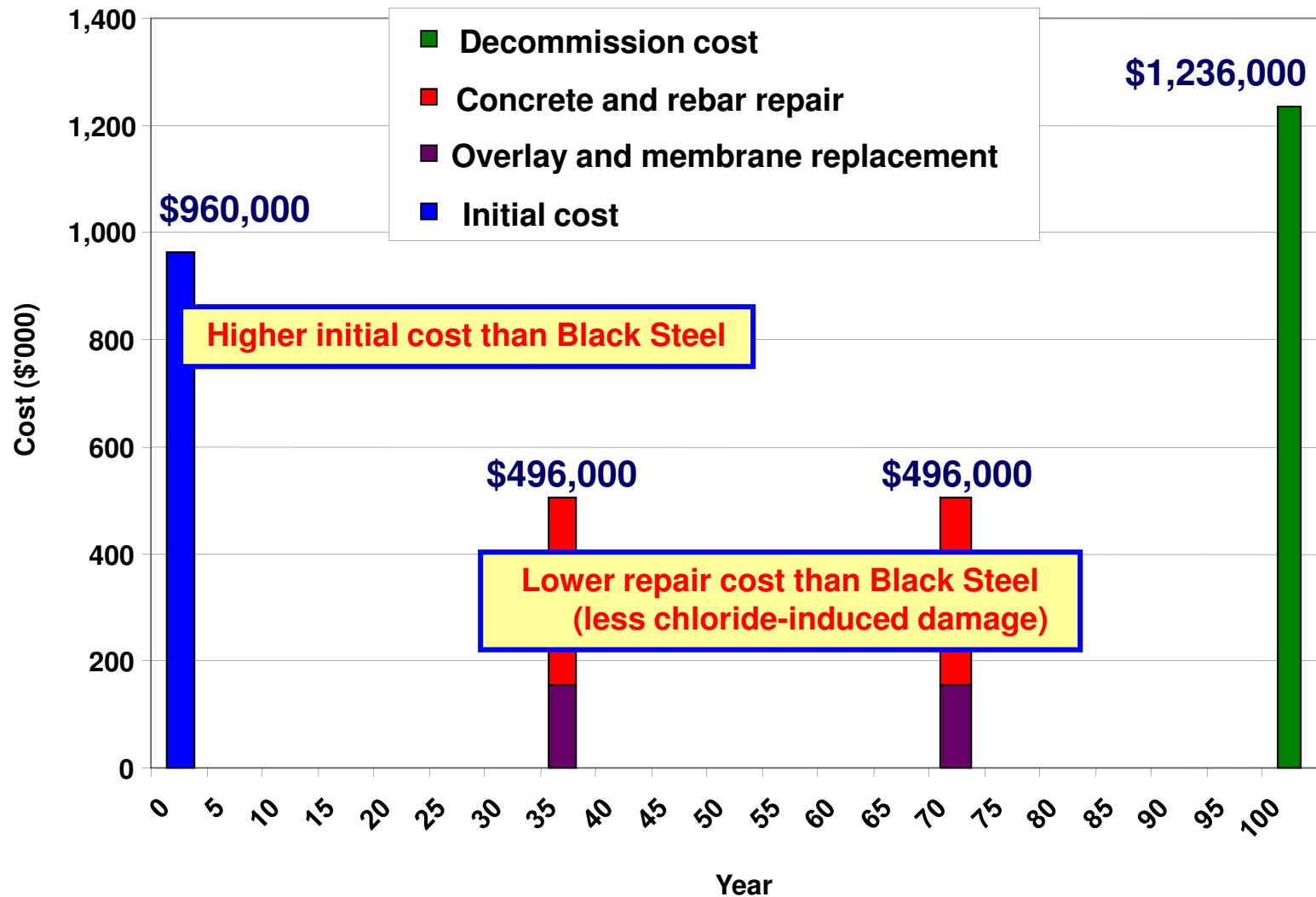

## Alternative 2: Epoxy-Coated

---

### Performance Problems

- Bars can still corrode despite high performance concrete
- Coating often fails – resulting corrosion can be comparable to that of black steel

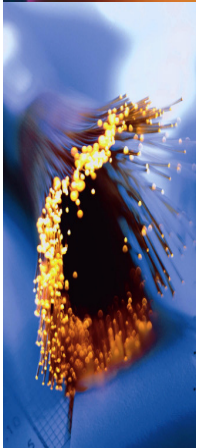
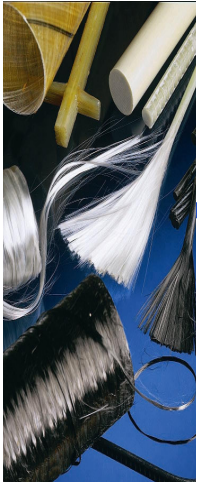

# Alternative 2: Epoxy-Coated Tornado Plot

- Concrete and rebar repair cycle (yrs)
- Unit concrete cost (\$/m3)
- Unit top mat cost (\$/m2)
- Unit bottom mat cost (\$/m2)
- Shallow depth repair (% of deck area)
- Partial depth repair (% of deck area)

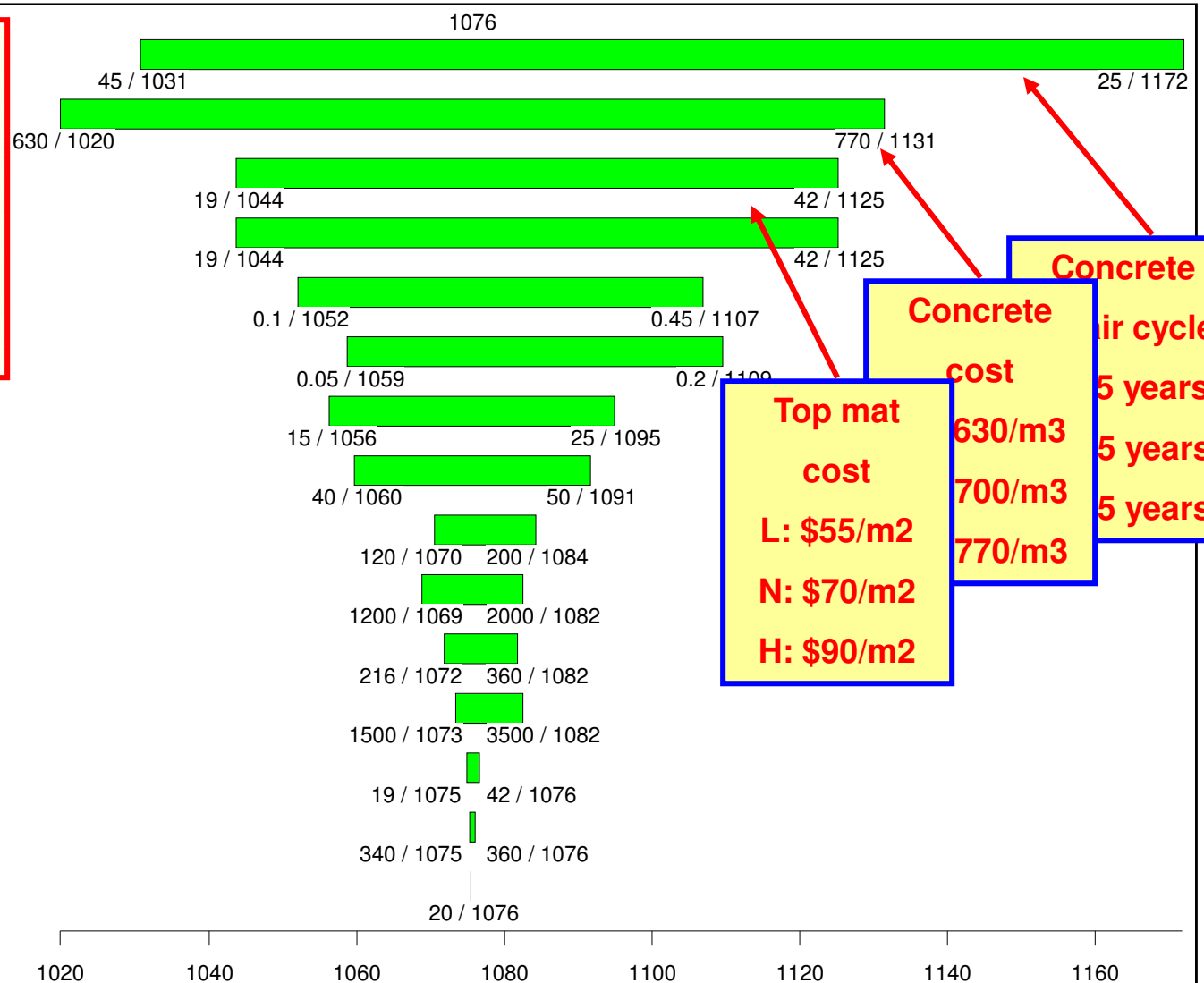

**Concrete**  
repair cycle  
5 years

**Concrete**  
cost  
630/m3  
700/m3  
770/m3

**Top mat**  
cost  
L: \$55/m2  
N: \$70/m2  
H: \$90/m2

# Alternative 2: Epoxy-Coated Distribution of Life Cycle Costs

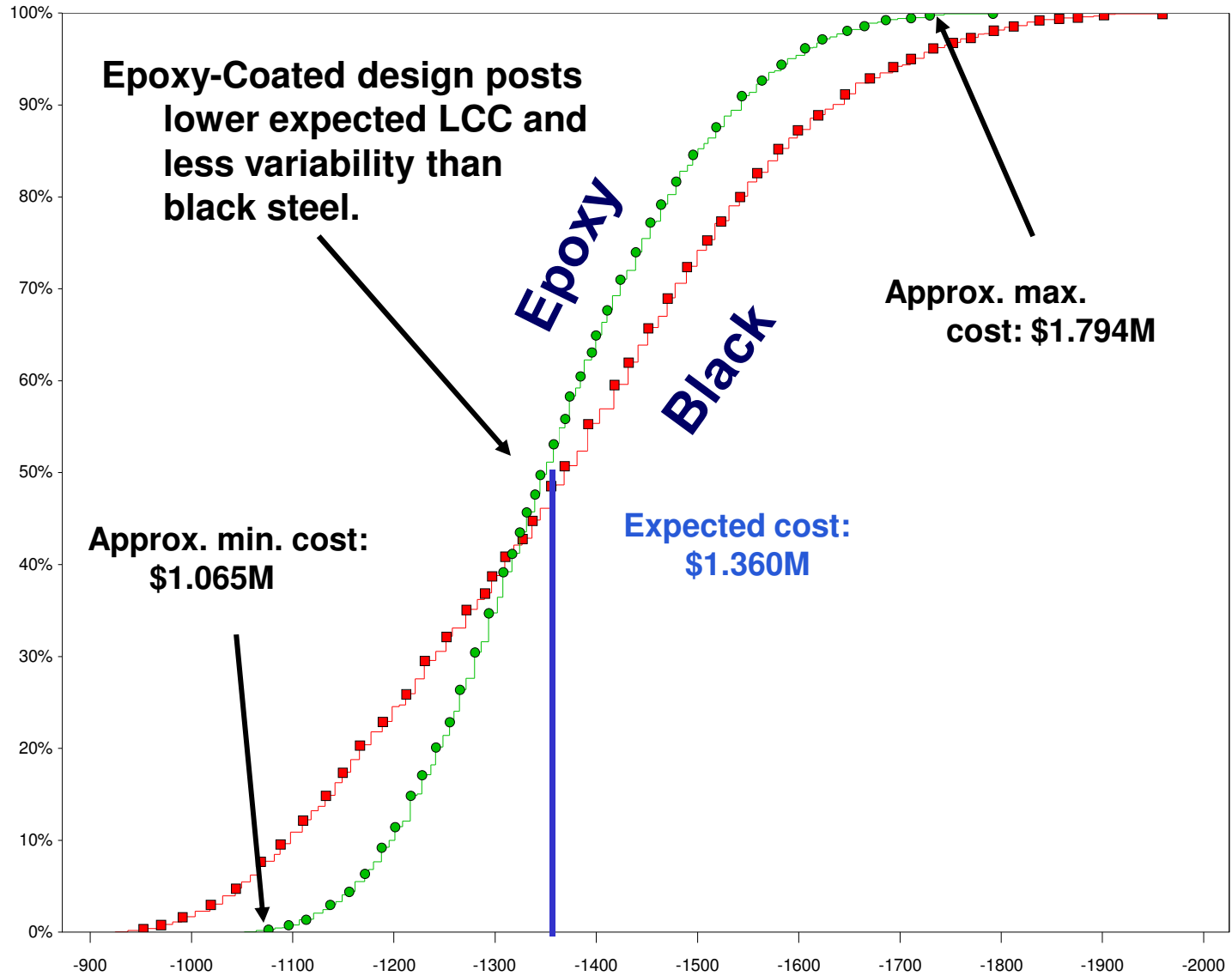

# Summary of Expected Value of Life Cycle Costs

Alternative	EVPW (\$M)
1. Black Steel	1.368
2. Epoxy-Coated	1.360
3.	
4.	
5.	

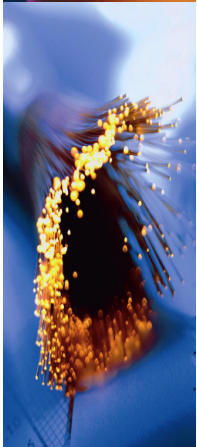

## Alternative 2: Epoxy-Coated

### Design Enhancements on Alternative 2:

- **Corrosion of reinforcement still an issue**
  - What if we substantially reduce corrosion potential?
- **Stainless Steel Reinforcing bars**
  - Higher corrosion threshold
  - Concrete cover can be reduced

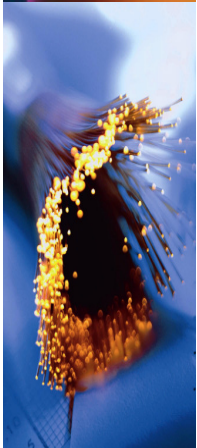
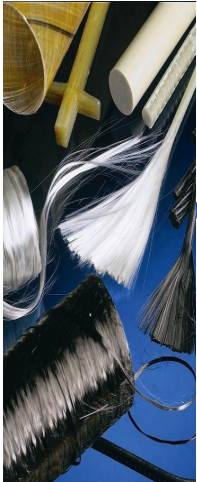

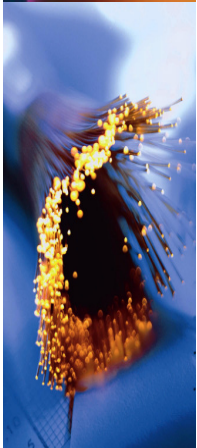
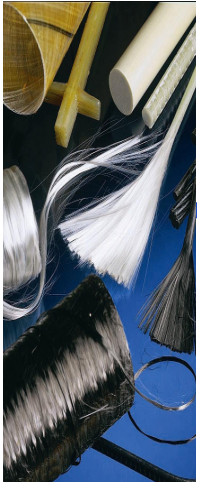

---

## **ALTERNATIVE 3: STAINLESS STEEL**

## Alternative 3: Stainless Steel

---

### Alternative 3: Internally reinforced with stainless and black steel bars

- Stainless bars in top mat
- Black steel bars in bottom mat
- Concrete cover reduced from 70mm to 45mm

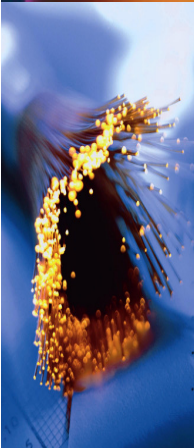

# Alternative 3: Stainless Steel

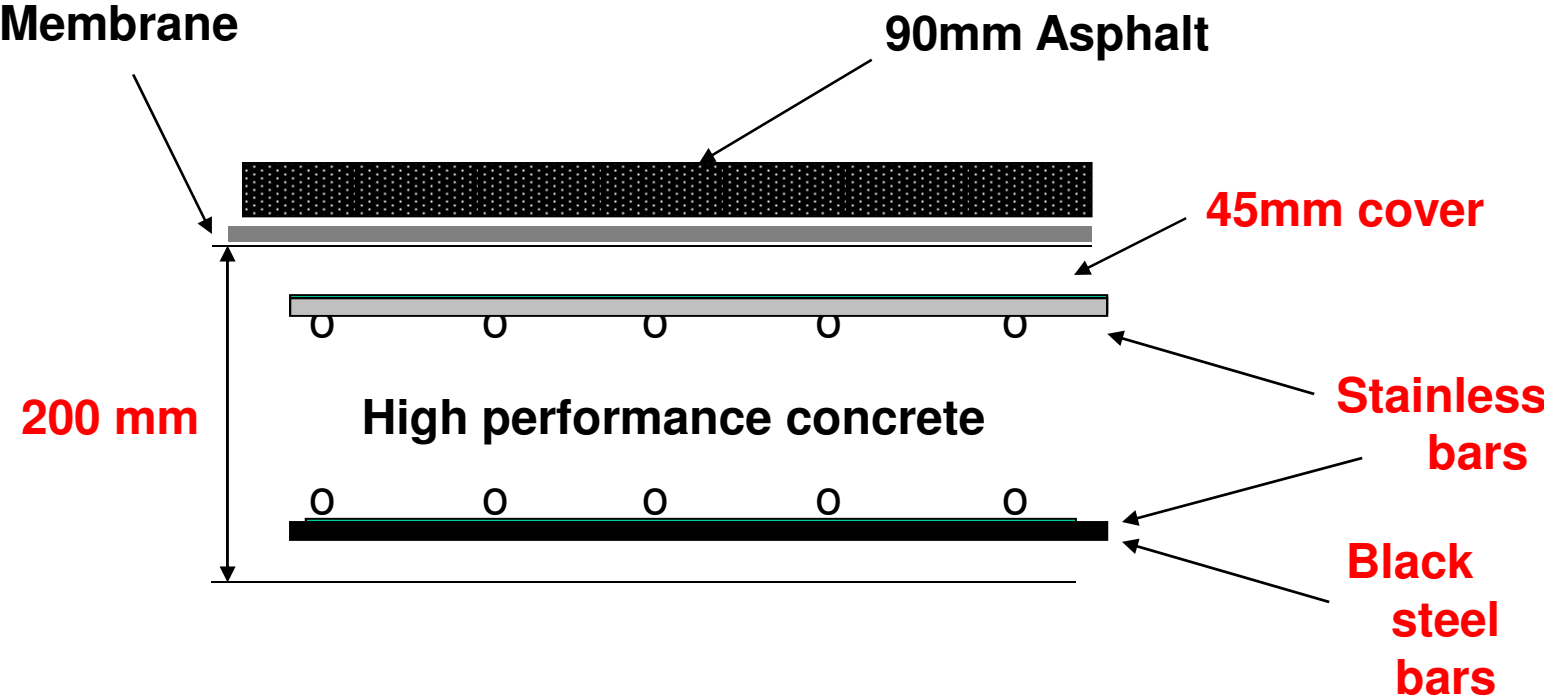

## Alternative 3: Stainless Steel

---

### Benefits over Alt. 2 (Epoxy-Coated):

- Bars can take a very long time to corrode...60 to 100 year life?
- Requires few corrosion precautionary measures
  - 70 mm concrete cover reduced to 45 mm





## Alternative 3: Stainless Steel

### Cash Flow Diagram (over 100 year life):

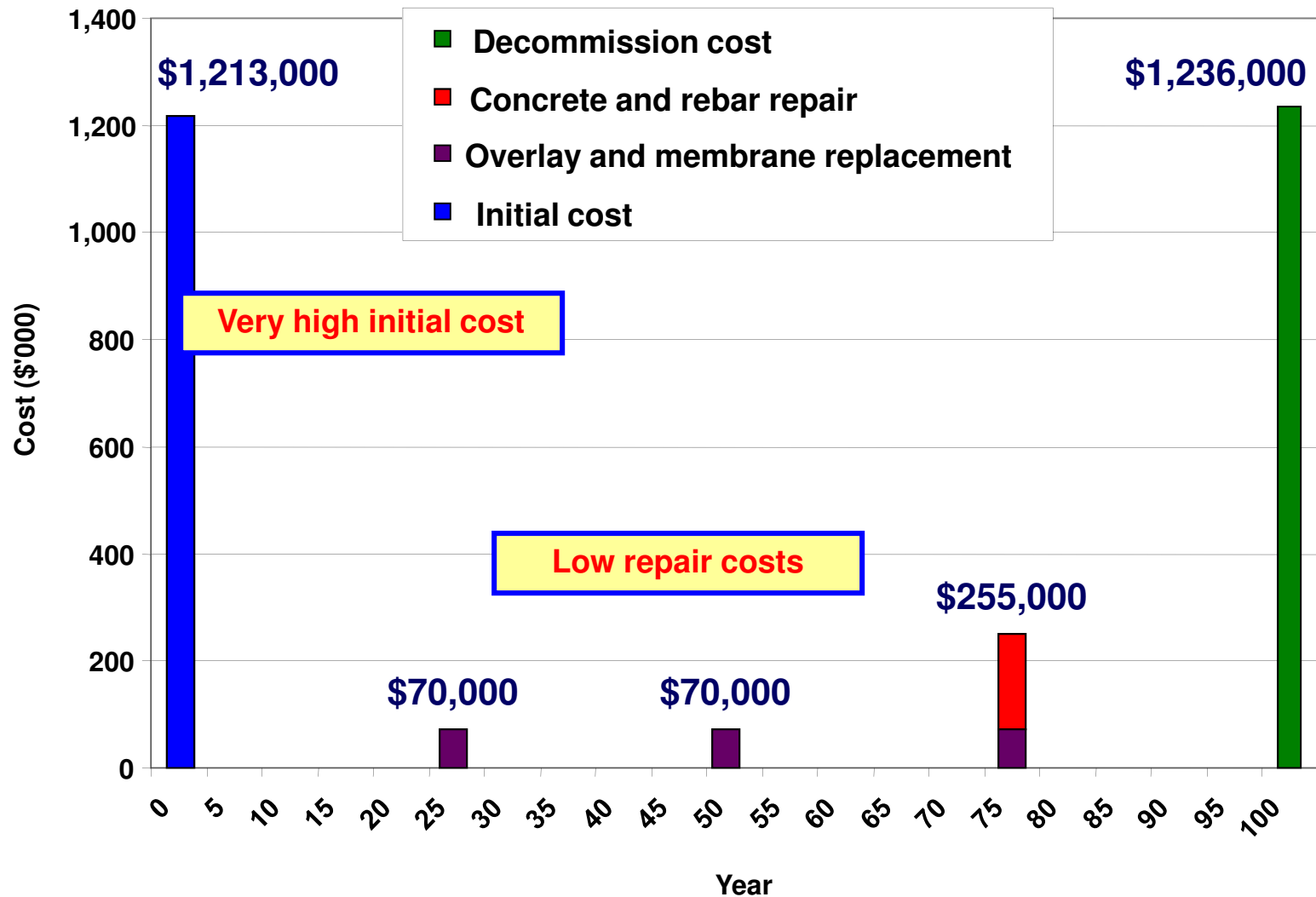

## Alternative 3: Stainless Steel

---

### Problems with design

- Higher life cycle cost
- Stainless steel costs 7x as much as black steel
- Stainless steel can still corrode

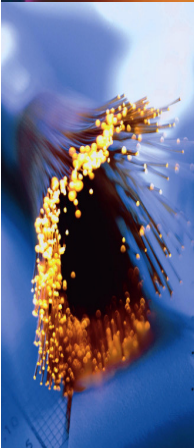

## Alternative 3: Stainless Steel

---

**How does uncertainty affect the results of  
Alternative 3?**

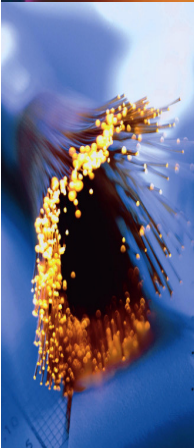

# Alternative 3: Stainless Steel Tornado Plot

- Unit top mat cost (\$/m2)
- Unit concrete cost (\$/m3)
- Unit bottom mat cost (\$/m2)
- Unit overlay cost (\$/m2)
- Unit membrane cost (\$/m2)

- Overlay replacement cycle (yrs)
- Concrete and rebar repair cycle (yrs)
- Traffic control cost (\$/day)
- Shallow depth repair (% of deck area)
- Partial depth repair (% of deck area)
- Shallow depth removal cost (\$/m2)
- Concrete replacement cost (\$/m3)
- Unit decommission cost (\$/m2)
- Partial depth removal cost (\$/m2)
- Unit rebar repair cost (\$/m2)

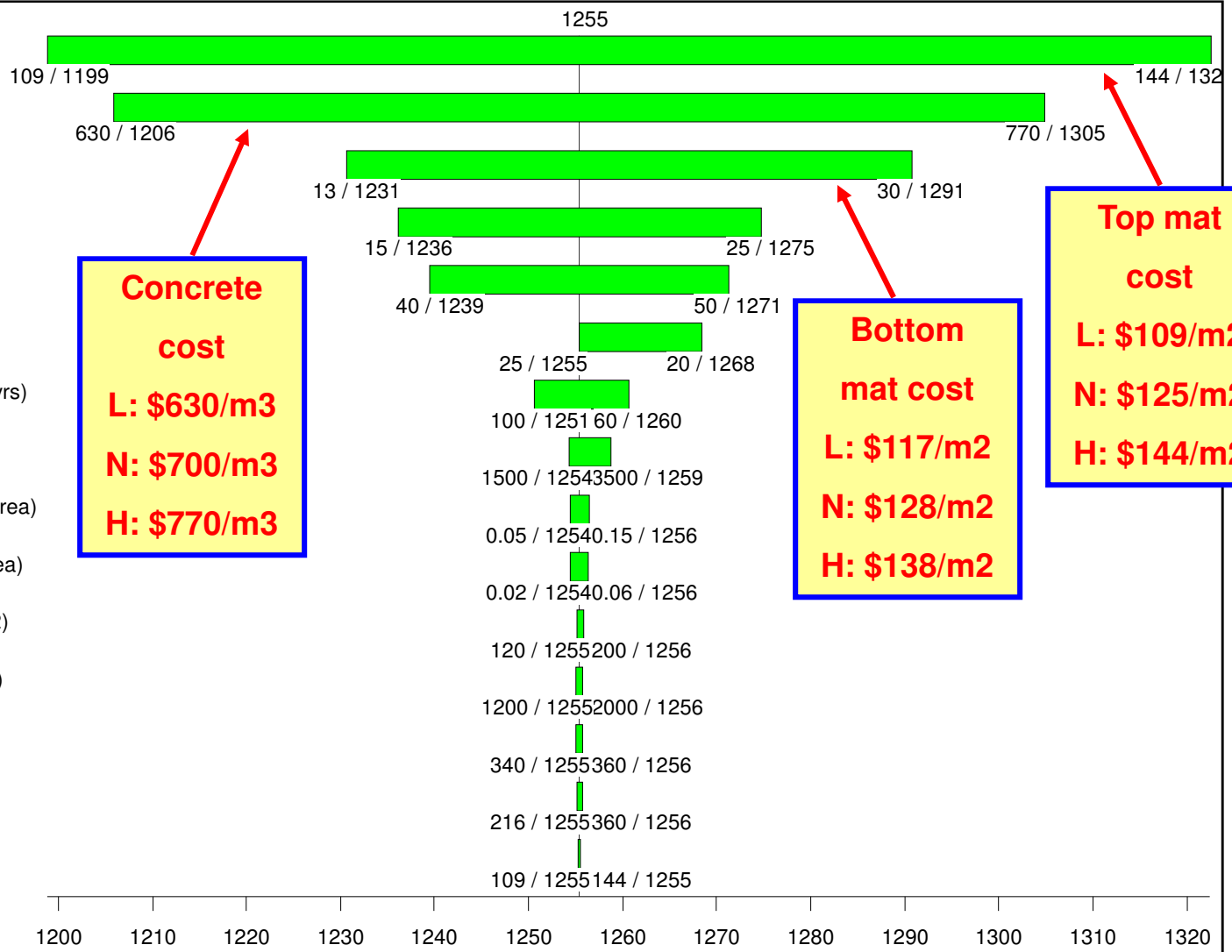

# Alternative 3: Stainless Steel Distribution of Life Cycle Costs

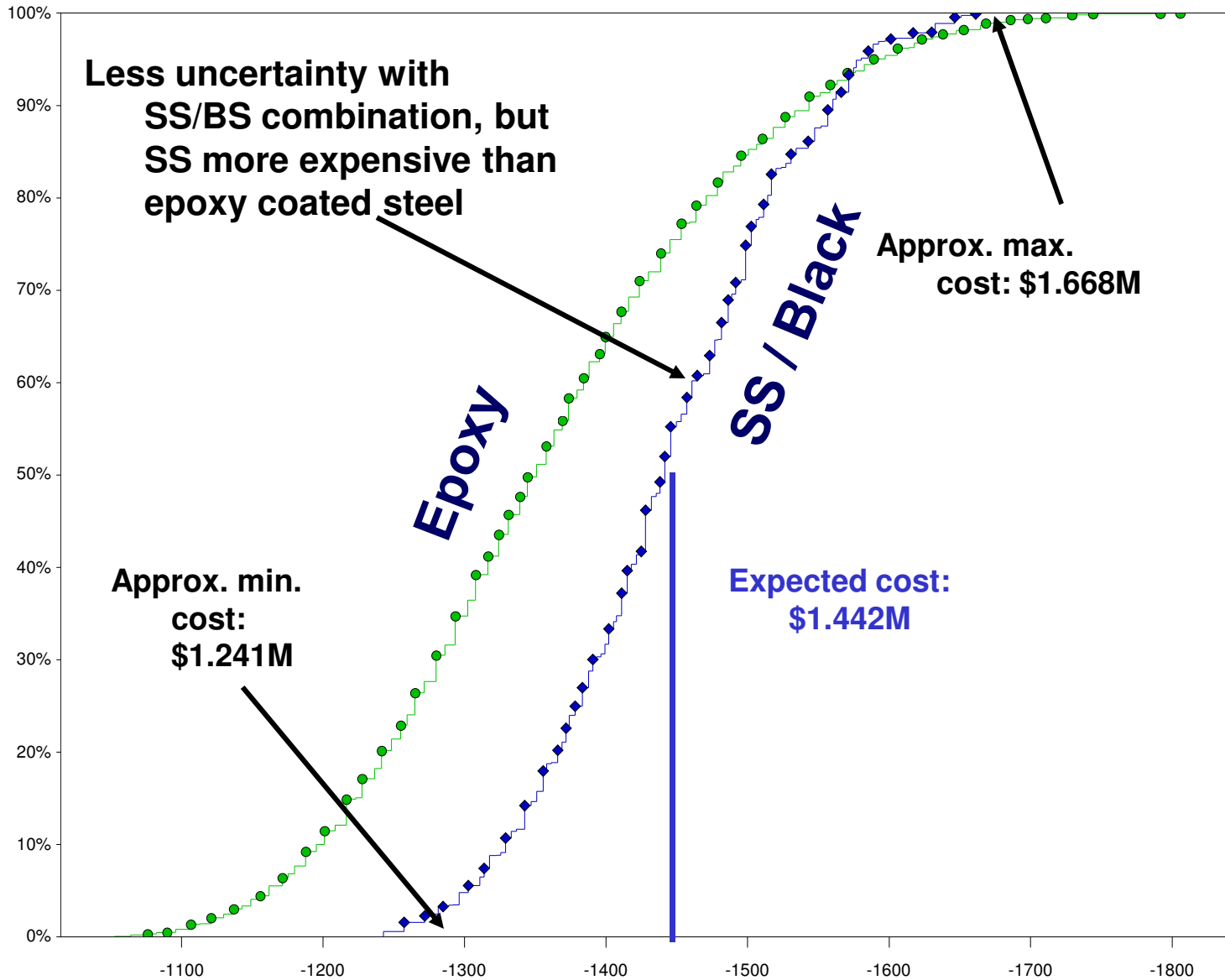



# Summary of Expected Value of Life Cycle Costs

Alternative	EVPW (\$M)
1. Black Steel	1.368
2. Epoxy-Coated	1.360
3. Stainless Steel	1.442
4.	
5.	



## Alternative 3: Stainless Steel

---

Although stainless design shows less uncertainty and good performance, it is more expensive.

What if we could get equal (or better) corrosion resistance at less than *one-third* the cost (slightly more than black steel)?

- **Substitute GFRP for Stainless Steel reinforcement.**

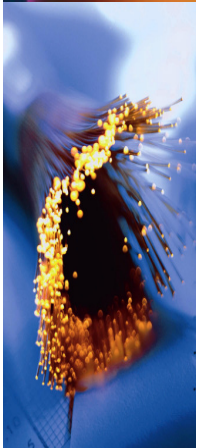
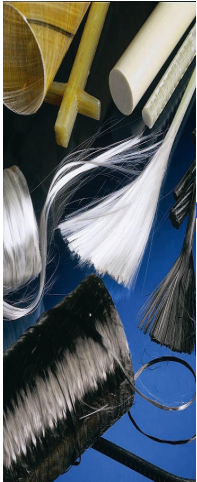

## ALTERNATIVE 4: GFRP

# Alternative 4: GFRP



Membrane

50mm HDC

45mm cover

200 mm

High performance concrete

GFRP bars

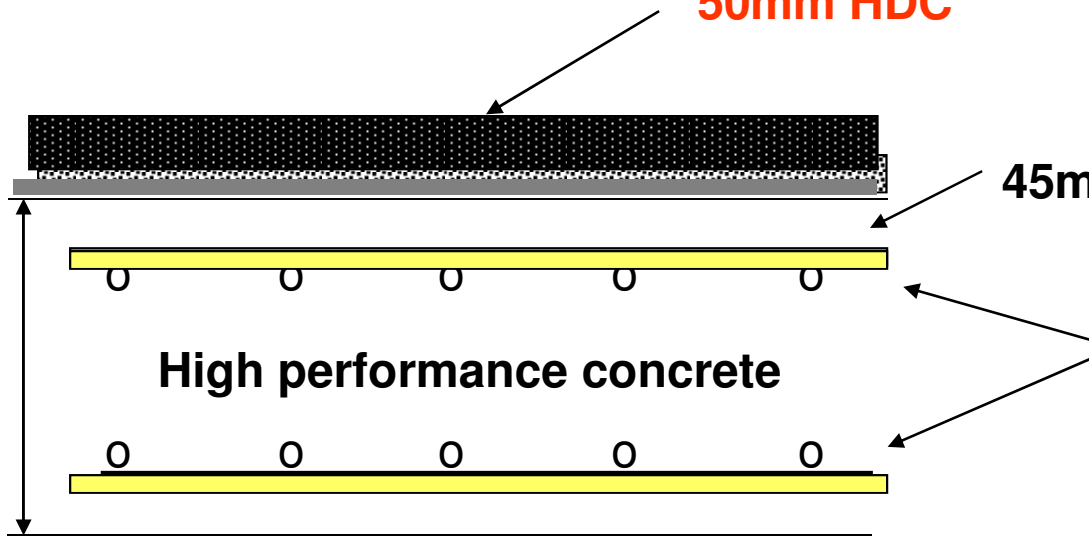

### Benefits over Alt. 3 (Stainless Steel):

- Resistant to chloride-induced corrosion.
- New Technology
  - Needs performance validation
    - (recent field, lab and modeling results are very promising)
  - But let's assess the economic potential
- Much less \$\$\$\$ than stainless steel and potentially more durable!

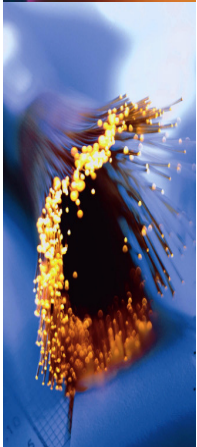



# Alternative 4: GFRP

## Cash Flow Diagram (100 year life):

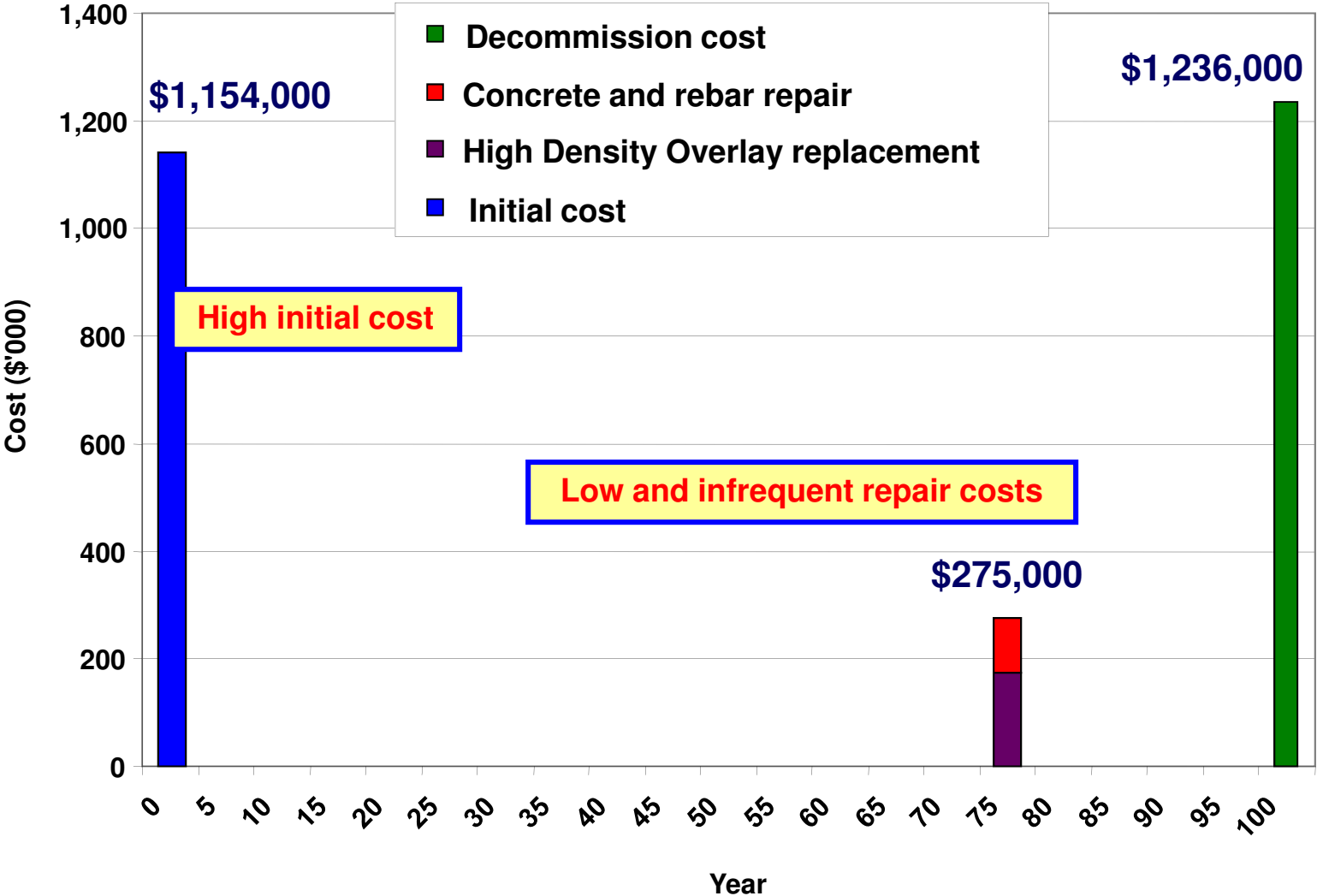

## Alternative 4: GFRP

---

**How does uncertainty affect the results of  
Alternative 4?**

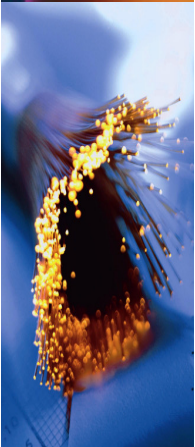

# Alternative 4: GFRP Tornado Plot

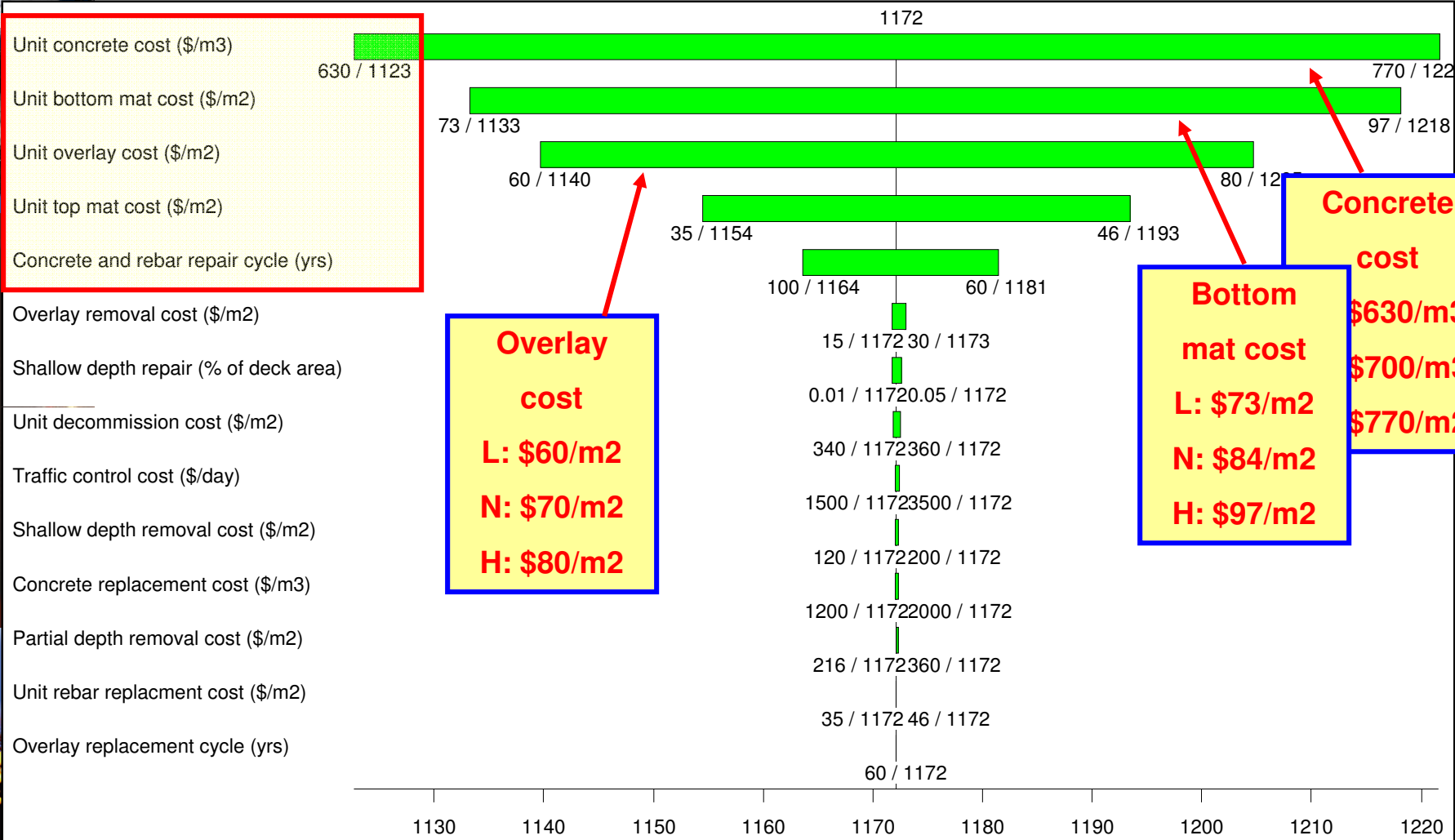

**Concrete cost**  
 \$630/m3  
 \$700/m3  
 \$770/m2

**Overlay cost**  
 L: \$60/m2  
 N: \$70/m2  
 H: \$80/m2

**Bottom mat cost**  
 L: \$73/m2  
 N: \$84/m2  
 H: \$97/m2

## Alternative 4: GFRP

---

**What is the uncertainty in using Alternative 4?**



# Alternative 4: GFRP Distribution of Life Cycle Costs

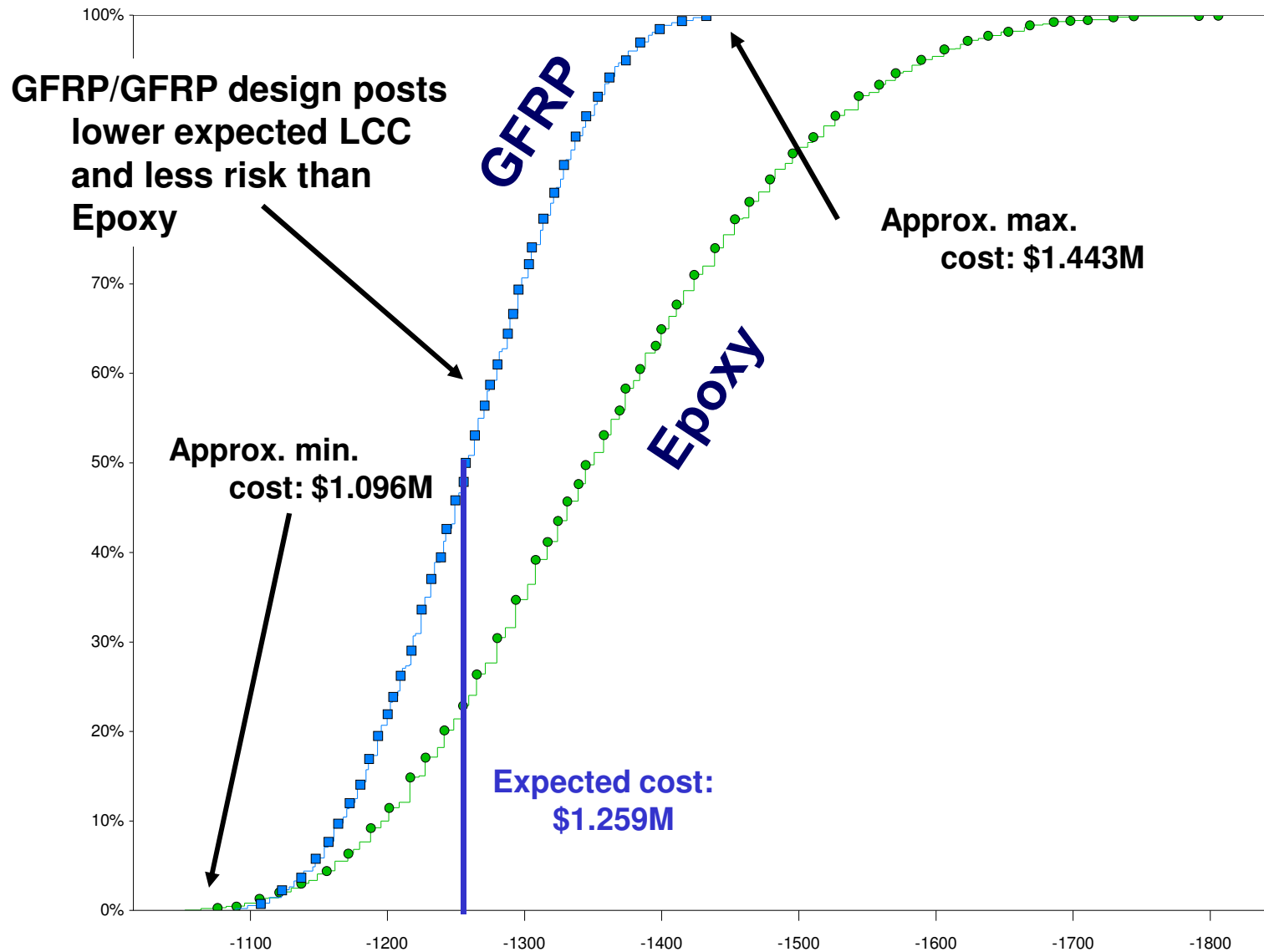

## Summary of Expected Value of Life Cycle Costs

Alternative	EVPW (\$M)
1. Black Steel	1.368
2. Epoxy-Coated	1.360
3. Stainless Steel	1.442
4. GFRP	1.259
5.	

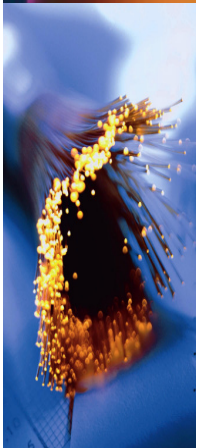
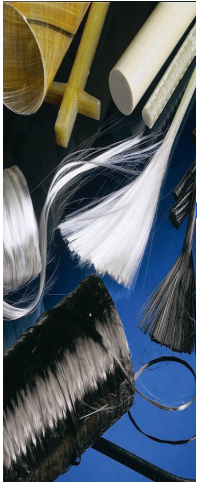

## Alternative 4: GFRP

**Internally restrained GFRP design performs reliably and predictably, but it is relatively pricey!**

**What if we can reduce the cost yet retain the performance characteristics?**

- **Use externally restrained design to reduce GFRP bar requirements.**
- **Employ external straps for restraint.**



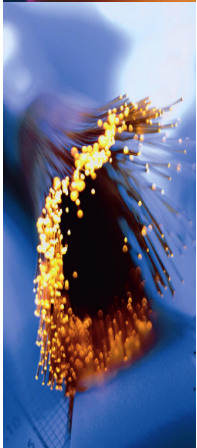
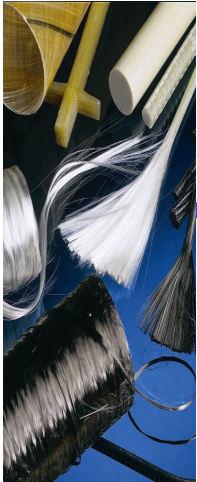

---

## **ALTERNATIVE 5: GFRP with Straps**

## Alternative 5: GFRP with Straps

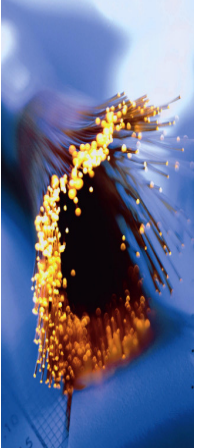

# Alternative 5: GFRP with Straps

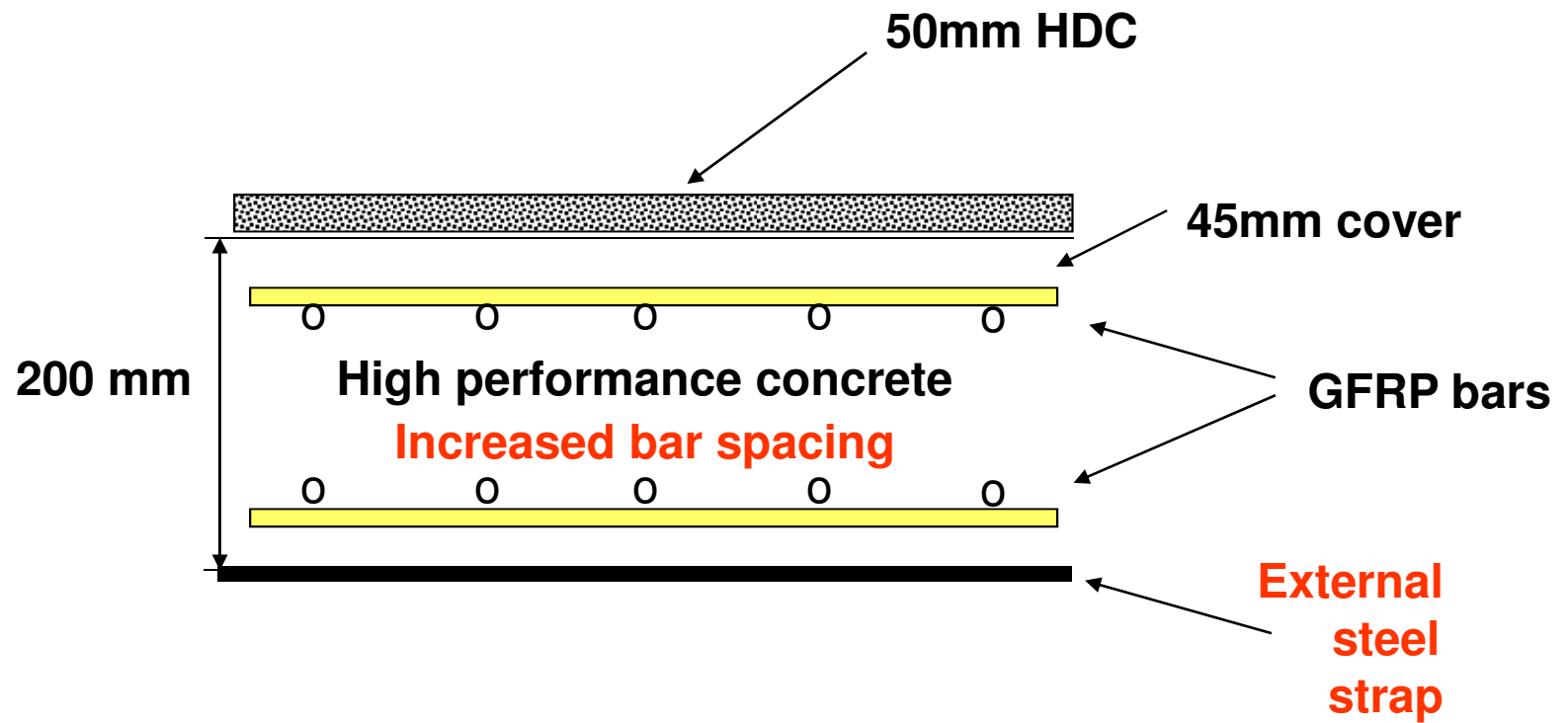
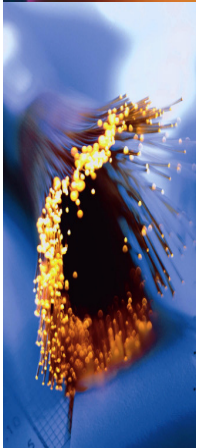

## Alternative 5: GFRP with Straps

---

### Benefits over Alt. 4 (GFRP):

- Same performance
- But lower cost since external straps reduce GFRP reinforcement requirements

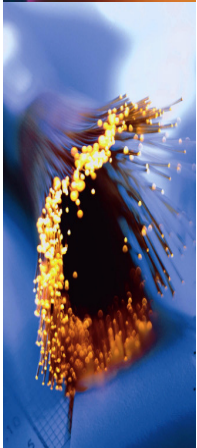
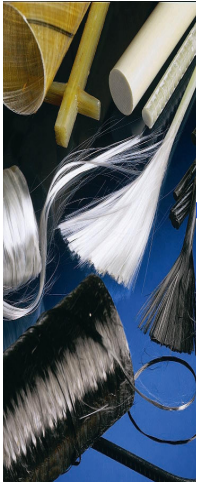

# Alternative 5: GFRP with Straps

## Cash Flow Diagram (100 year life):

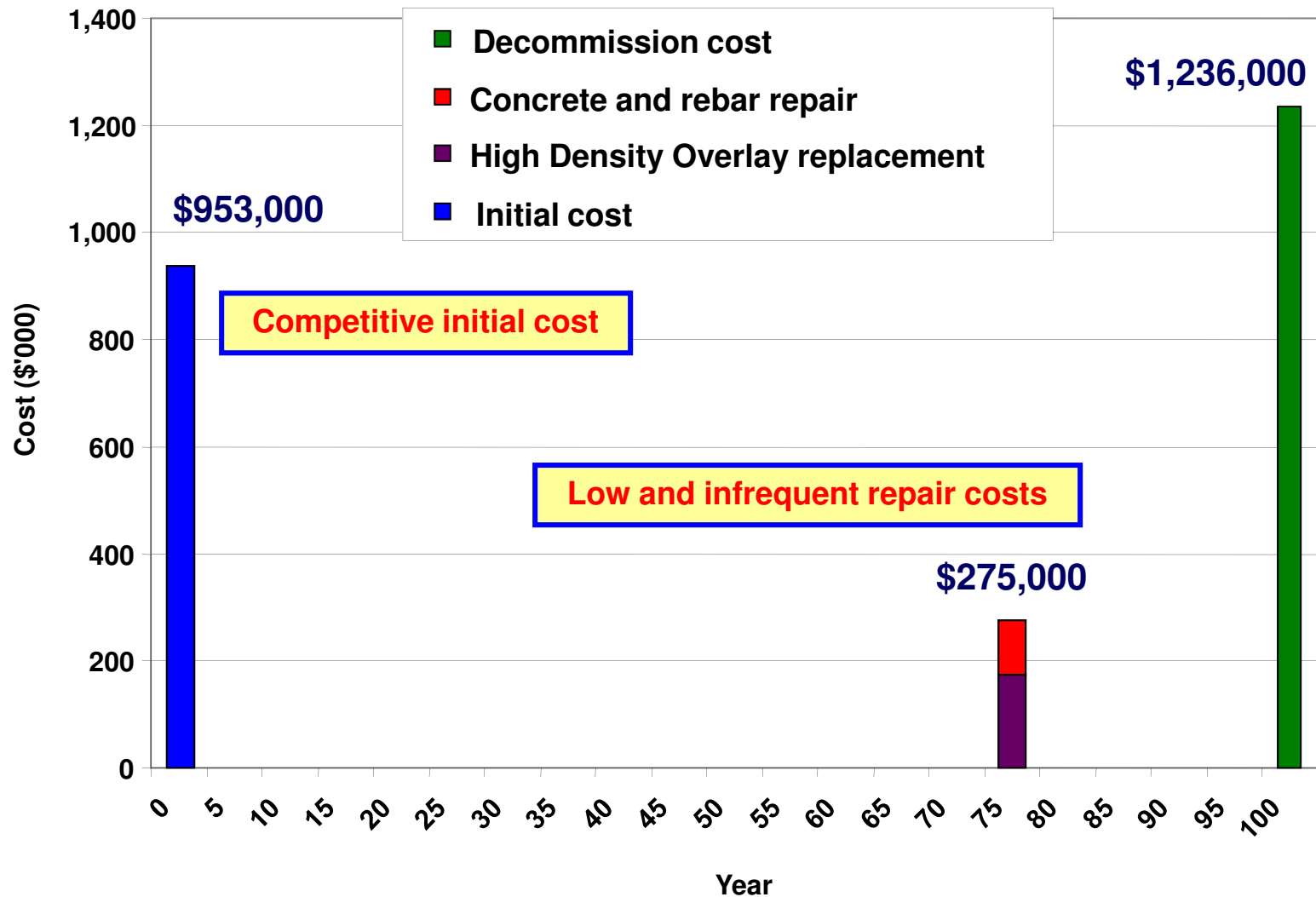

# Alternative 5: GFRP with Straps Tornado Plot





# Alternative 5: GFRP with Straps Distribution of LCC

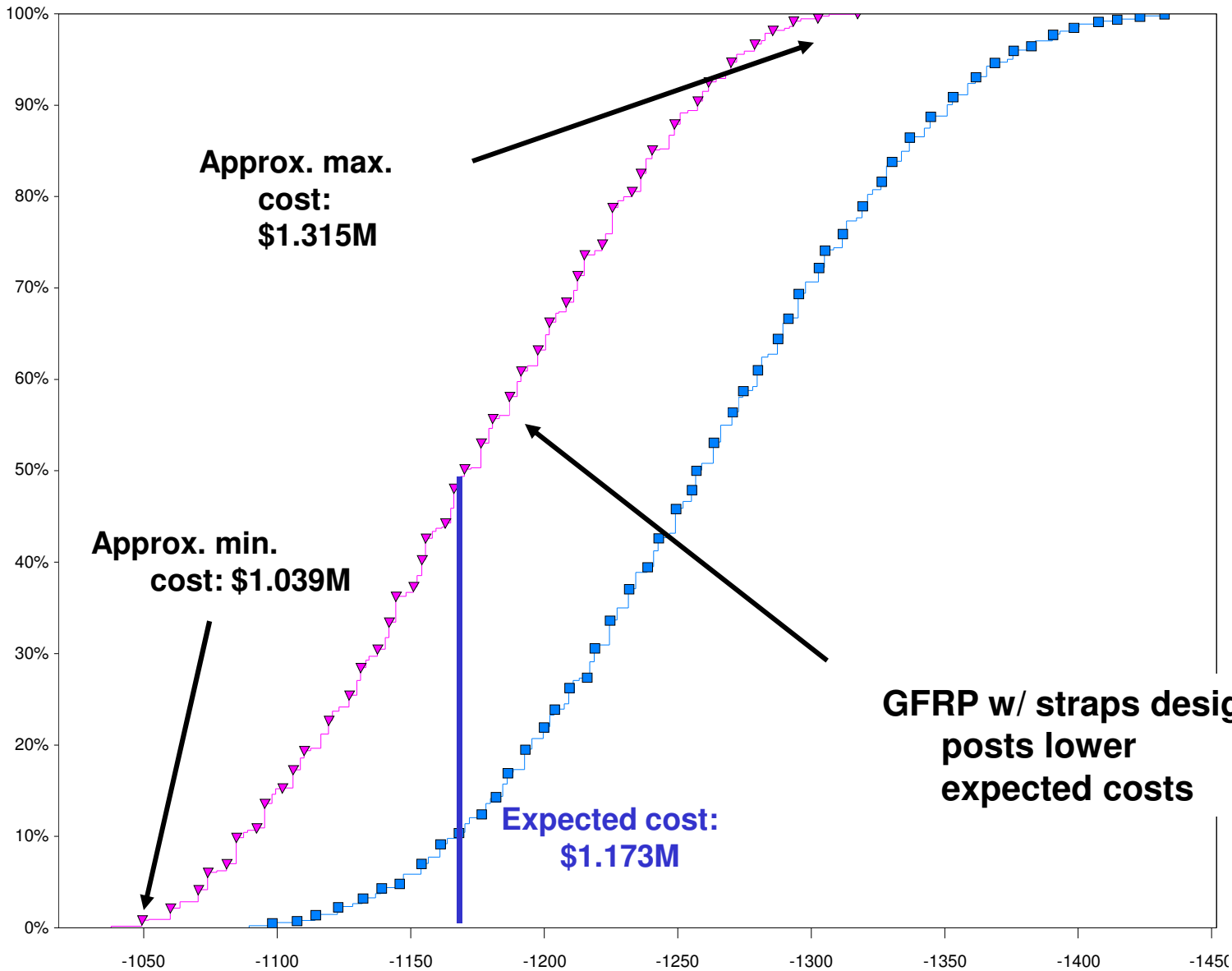

## Summary of Expected Value of Life Cycle Costs

Alternative	EVPW (\$M)
1. Black Steel	1.368
2. Epoxy-Coated	1.360
3. Stainless Steel	1.449
4. GFRP	1.259
5. GFRP with Straps	1.173

**Expected value of Life Cycle Costs of the GFRP design (with straps) is 15% to 23% less than the other alternatives.**

## Bridge Deck Application

### Conclusion:

- **GFRP design (with straps) has**
  - **2<sup>nd</sup> lowest initial construction cost**
  - **Lowest life cycle cost over 100 years**
    - **Expected value savings of 15%-30% over other alternatives**
  - **Stochastic dominance and little risk**
    - **LCC is far less sensitive to ‘sub-optimal’ maintenance strategies**
- **GFRP deserves a serious look!**



# Summary of Methodology

